

**CUSTOM UNIT WHICH IS NOT LISTED OR CERTIFIED WITHIN AHRI UNIT COOLERS CERTIFICATION PROGRAM, BUT IS RATED IN ACCORDANCE WITH AHRI STANDARD 420.**

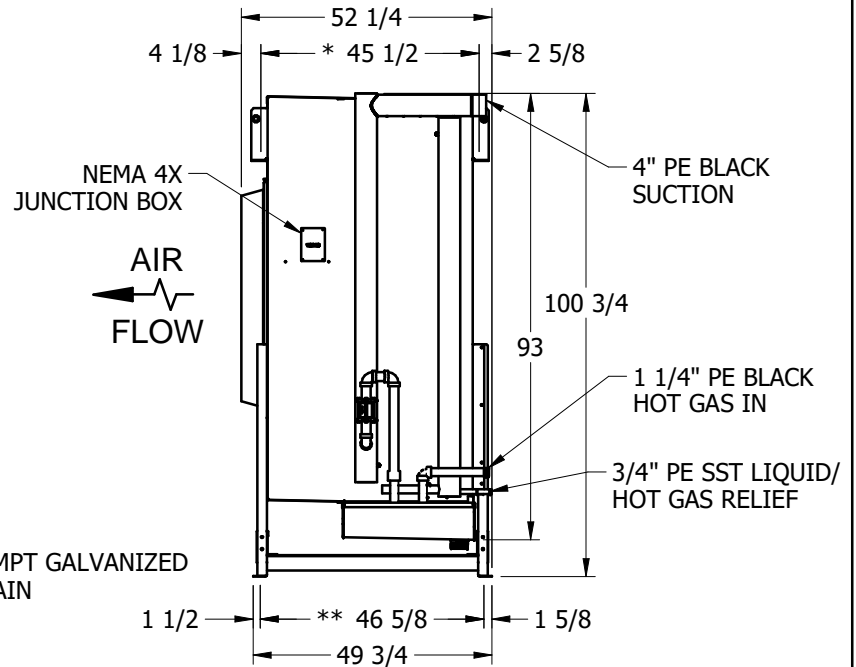
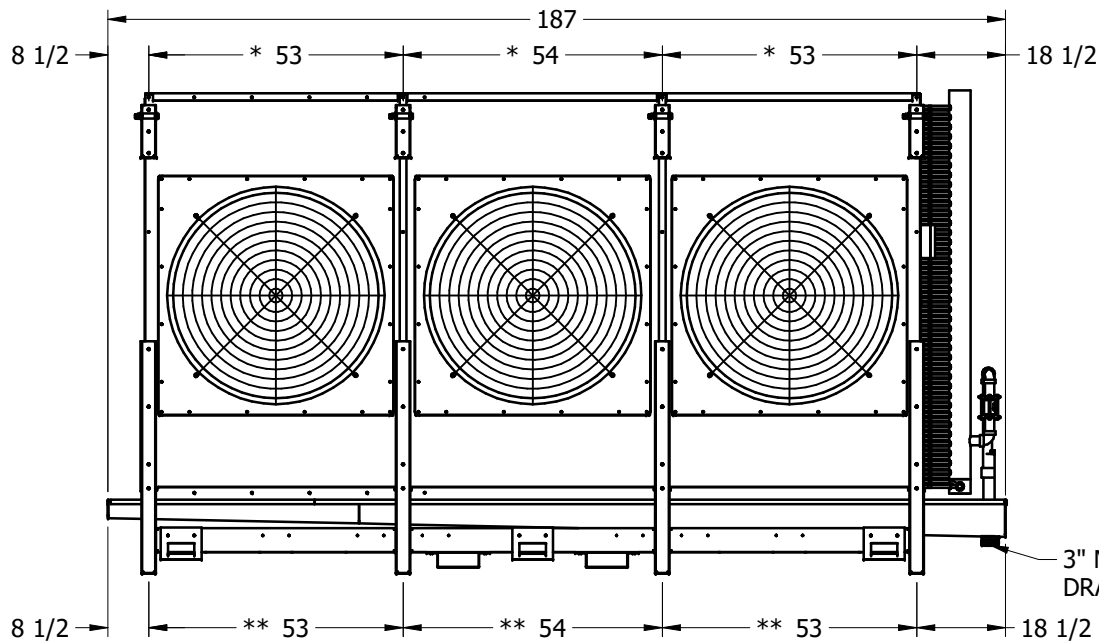
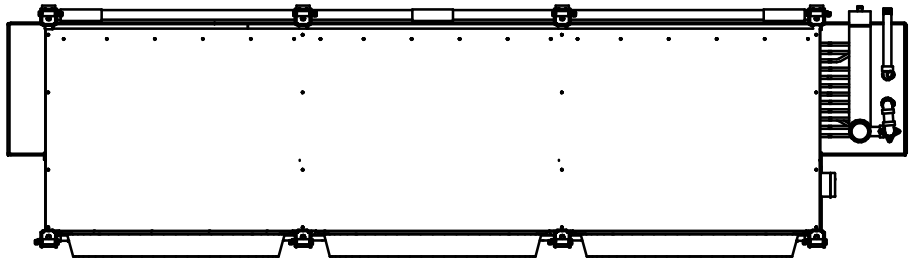

**NOTES:**

- (1) ALL HANGER AND LEG HOLES ARE 13/16Ø.
- (2) THE EVAPORATOR CONNECTION SIZES (SHOWN) DO NOT NECESSARILY CORRESPOND TO THE APPROPRIATE SYSTEM PIPE SIZES.
- (3) DO NOT SCALE DRAWING. CONNECTION LOCATIONS ARE APPROXIMATE; DO NOT USE FOR FABRICATION OF PIPING.
- (4) 5.0 PSI LIQUID FEED PRESSURE REQUIRED ABOVE COIL SATURATED SUCTION PRESSURE.

**\*HANGER HOLE LOCATIONS**

**\*\*CENTERLINE OF LEGS**

|               |                                     |                                   |  |                                    |
|---------------|-------------------------------------|-----------------------------------|--|------------------------------------|
| QTY. <b>3</b> | MODEL <b>TFCSRB3-89123E2000K1MA</b> | SERIAL NUMBER <b>16-782831-33</b> | CERTIFIED FOR <b>PERMACOLD ENGINEERING</b> | PROJECT <b>HARRY'S FRESH FOODS</b> |
|---------------|-------------------------------------|-----------------------------------|--|------------------------------------|

APPLICATION RATING: [ ] WET [X] DRY  
 47.0 TONS ( 564,000 BTUH ) @ 10°F TD  
 -25°F ROOM TEMP. -35°F SST - WB  
 R-717 REFRIGERANT BOTTOM FEED  
 -35°F LIQ. FEED TEMP. 1.2:1 RECIRC. RATE  
 - dBA @ 6 FT PER UNIT, FREE FIELD

FAN/MOTOR DATA:  
 64,800 CFM @ 1.5" ESP  
 730 FPM FACE VELOCITY  
 (3) 20 HP TEAO FAN MOTOR(S)  
 1750 RPM 460/3/60 SERVICE  
 33.3 DESIGN MOTOR AMPS  
 42" FAN DIAMETER

PHYSICAL DATA:  
 88.89 SQ. FT. FACE AREA  
 13.0 CU. FT. COIL VOLUME  
 12 ROWS DEEP 3.3 FPI  
 7,236 LBS. NORMAL OPERATING WEIGHT  
 6,060 LBS. SHIPPING WEIGHT

|                        |                           |
|------------------------|---------------------------|
| ROOM <b>-25°F ROOM</b> |                           |
| REFERENCE              | APP. VERSION <b>5.1.0</b> |



P.O. Box 1300  
 Westminster, Maryland 21158 USA  
 Phone (410)756-2600  
 Fax (410)756-6450

REV:1) 4/22/16 TMS DATE: 3/31/16 RDK

REMARKS: SMALL DIAMETER STAINLESS STEEL EMBOSSED TUBE, ENHANCED ALUMINUM FIN COIL, G-235 GALVANIZED STEEL CASING, PAN AND PAN COVER, HOT GAS DEFROST COIL AND PAN, INCLUDES 1 1/2" CHECK VALVE AND INTERCONNECTING PIPING, PREMIUM EFFICIENCY INVERTER READY MOTORS, UNIT MUST BE COVERED BEFORE SHIPMENT USING TARP OR WRAP, REVERSIBLE FANS.

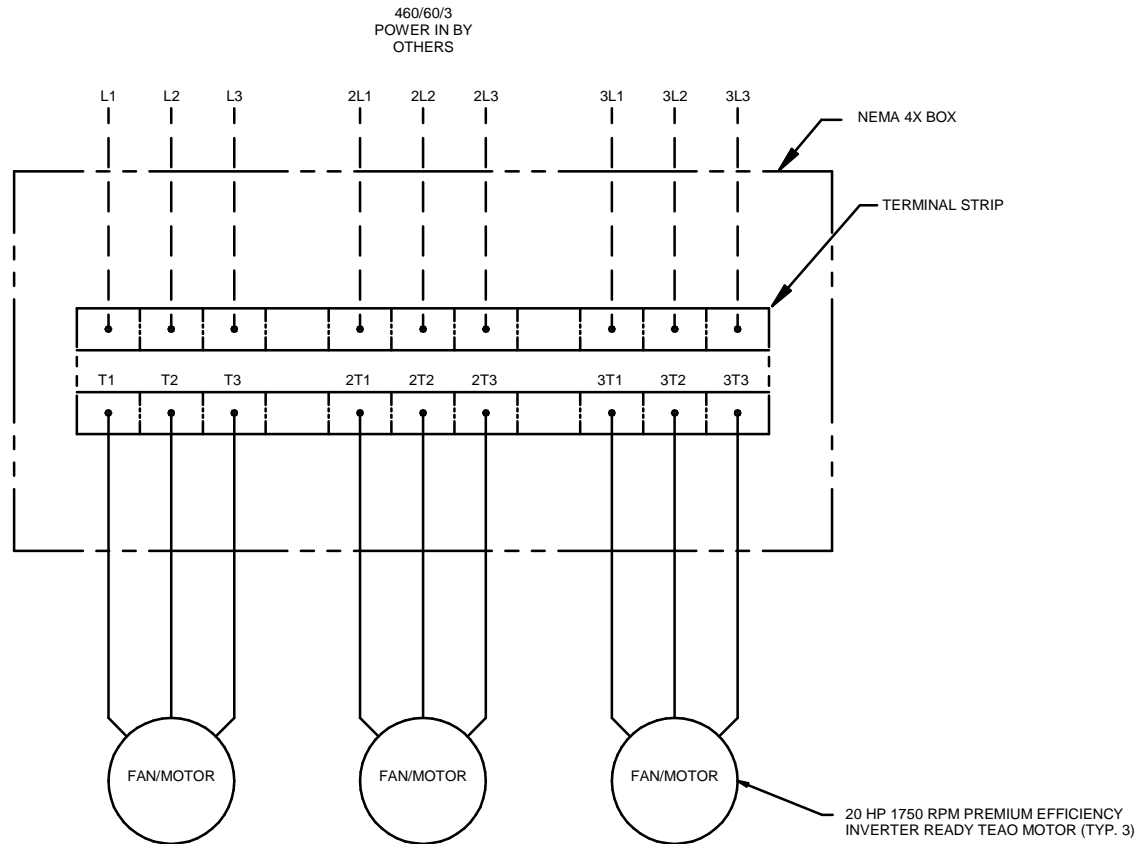

--- DASHED LINES REPRESENT  
WIRING BY OTHERS

— SOLID LINES REPRESENT  
WIRING BY EVAPCO

REV 1) TMS 4/22/16

|  |   |                                 |                                  |   |                                     |
|--|---|---------------------------------|----------------------------------|---|-------------------------------------|
| QTY.   | 3 | MODEL<br>TFCSRB3-89123E2000K1MA | SERIAL<br>NUMBER<br>16-782831-33 | CERTIFIED<br>FOR<br>PERMACOLD ENGINEERING | PROJECT<br>HARRY'S FRESH FOODS      |
| CONFIDENTIAL<br>This document is the property of Evapco, Inc. It should not<br>be copied or disclosed without prior written authorization. |   |                                 |                                  | TITLE<br><b>ELECTRICAL SCHEMATIC</b>      | DRAWN<br>BY<br>RDK<br>CHECKED<br>BY |
|  |   |                                 |                                  |   | EVAPCO, INC.                        |